

# Thermal Oil and Hot Water Pumps: Reliable by Design

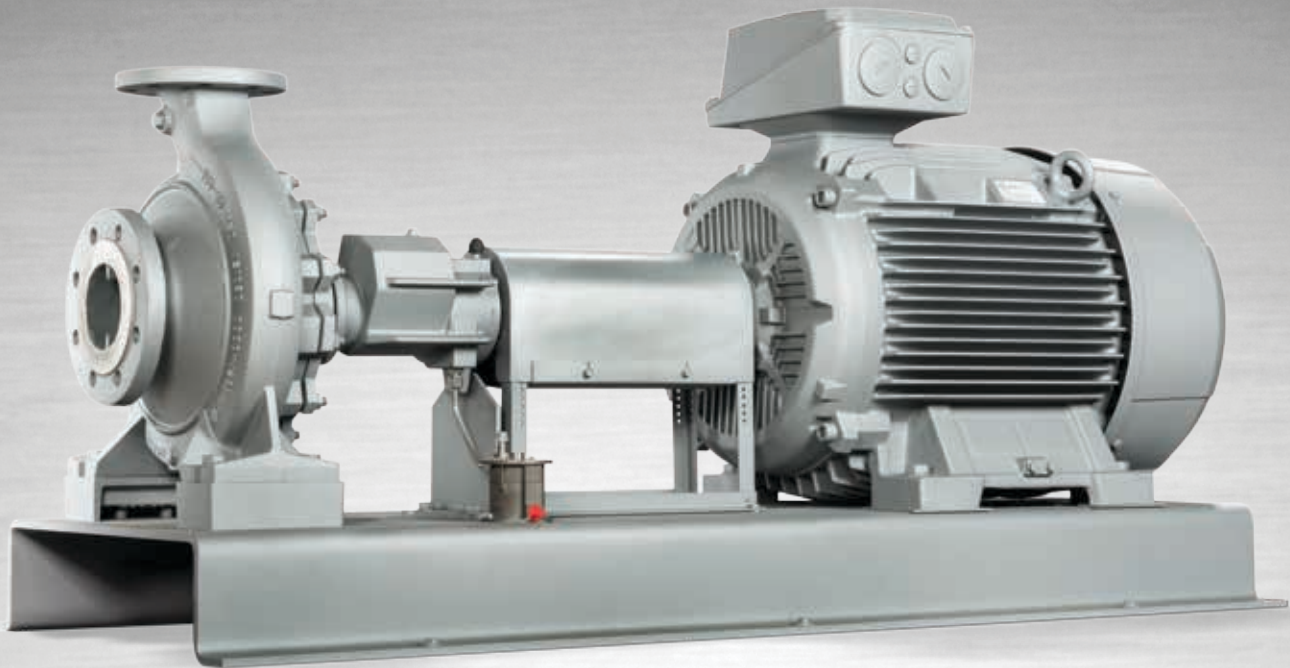

Etanorm SYT with Leakage Monitoring Unit

### Applications:

- Heat transfer systems (DIN 4754, VDI 3033)
- Hot water circulation

More information: [www.ksb.com/products](http://www.ksb.com/products)



Etaline SYT



Etabloc SYT



Etanorm SYT, KSB SuPremE®-IE5 motor\*, wall-mounted PumpDrive



Etanorm RSY

# Thermal Oil and Hot Water Pumps: Reliable by Design

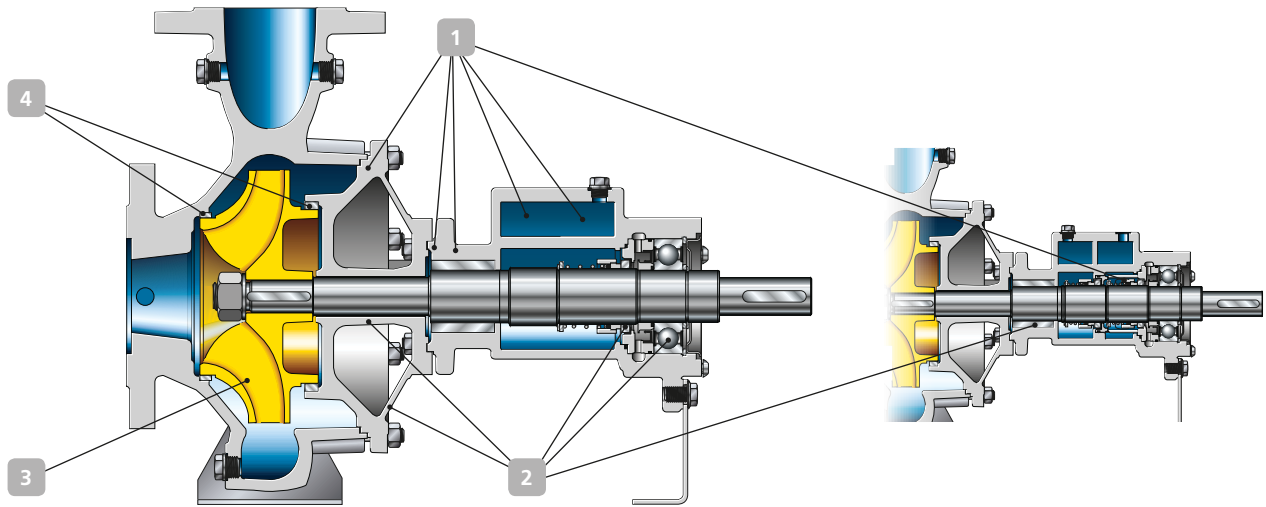

## 1 Maximum operating reliability

- Highly effective venting contour VenJet ensures optimum venting
- Optional: Single mechanical seal with leakage monitoring unit for a reliable control of the seal's condition
- Confined gaskets
- Design variant with double mechanical seal in tandem arrangement
- Anti-seize carbon plain bearing lubricated by the fluid handled
- Shaft seal rings between mechanical seal and bearing protect the deep groove ball bearing against ingress of the heat transfer fluid
- Impeller secured by Nord-Lock washers for even higher operating reliability throughout the entire life cycle

## 2 Robust design

- Sturdy discharge cover designed for high stiffness
- Optimised heat barrier, little wear
- Design variant with SiC/SiC bearing for high resistance

- Reinforced C4-type deep-groove ball bearing with special grease fill for long service life

## 3 High energy efficiency

- Optimised hydraulic system yields high efficiency
- Impeller trimmed to match the specified duty point
- Suitable for variable-speed operation in combination with IE3 and KSB SuPremE® IE5 motor\* as standard

## 4 Easy to service

- Replaceable wear rings and straightforward dismantling of bearing bracket

## Versatile

- Also available in close-coupled and in-line design.
- Hydraulic test run to ISO 9906 2B, 3B or 2U available
- NEMA motors available
- Flange can either be selected to EN or ASME as standard

\* IE5 in accordance with IEC/TS 60034-30-2 up to 15/18.5 kW (only for 1500 rpm types rated 0.55 kW, 0.75 kW, 2.2 kW, 3 kW, 4 kW; IE5 in preparation)

### Materials

Volute casing	EN-GJS-400-15 / 536 GR 60-40-18
Discharge cover	EN-GJS-400-15 / 536 GR 60-40-18
Shaft	1.4021+QTHRC55
Impeller	EN-GJL-250/A48 CL 35B
Casing wear rings	Grey cast iron
Bearing bracket	EN-GJS-400-15 / 536 GR 60-40-18

### Technical data\*\*

		Etabloc SYT	Etaline SYT	Etanorm SYT/RSY	
Flow rate up to		280/337	316/228	1,900/2,280	m <sup>3</sup> /h
Head up to		68/99	69/101	102/90	m
Fluid temperature	Thermal oil	-30 to +350	-30 to +350	-30 to +350	°C
	Hot water	-30 to +180	-30 to +180	-30 to +180	
Operating pressure up to		16	16	16	bar

\*\* Values for 50 Hz/60 Hz

Automation option: PumpDrive



KSB SE & Co. KGaA  
Johann-Klein-Straße 9  
67227 Frankenthal (Germany)  
www.ksb.com